



# ecoGEO+ B/C PRO & AU

R290

1-6kW AU6/2-10kW AU12/4-16kW AU22

Air Source System Using Brine to  
Water Heat Pumps with Dry Coolers



# ecoGEO<sup>+</sup> B/C PRO & AU



## Models

ecoGEO <sup>+</sup> 1-6 PRO & AU6		Single-phase 230 Vac	Three-phase 400 Vac
ecoGEO <sup>+</sup> 2-10 PRO & AU12			
ecoGEO <sup>+</sup> 4-16 PRO & AU22			

## Brine to water heat pump with air as heat source

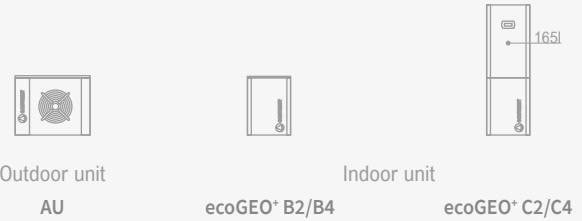

## Services



## Compatible production systems



## Management of shunt groups

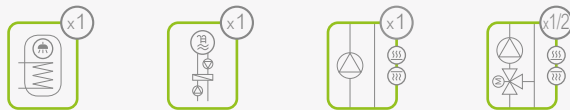

## Performance



## Cascade

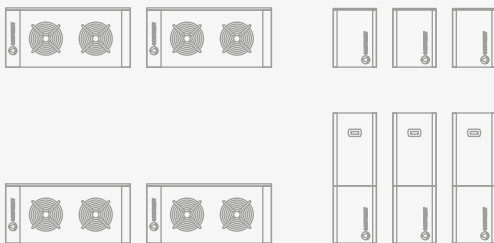

## Characteristics

- Modulating thermal output control across a wide range (17%–100%), fan speed control (20%–100%), and modulating flow control in both source and production circuit (20%–100%).
- Natural refrigerant R290: GWP 3.
- Inverter technology.
- Compact design including source and production circulators, 8L and 12L expansion vessels for source and production respectively, source and production safety valves, and a DHW 3-way valve.
- High Temperature Recovery (HTR) system for domestic hot water (DHW) production up to 70 °C without auxiliary support, and simultaneous DHW and heating/cooling production in ecoGEO+ B/C 2-10 PRO and ecoGEO+ B/C 4-16 PRO models.
- Integrated control of up to three different flow temperatures, two buffer tanks (heating and cooling), one DHW tank, one swimming pool, and time scheduling of DHW recirculation.
- Integrated management of modulating air source units for use in air source or hybrid air-ground source systems.
- Integrated control of external auxiliary backup systems—on/off or modulating (electric heaters, boilers, etc.).
- Cascade control for up to three heat pumps.
- Exclusive defrost management.
- Active cooling via cycle inversion integrated in B4/C4 models.
- Models available in single-phase and three-phase versions.
- Integrated photovoltaic hybridisation.
- Integrated energy meters for monitoring electrical consumption, thermal output (heating/cooling), and instantaneous as well as seasonal efficiency monthly and annual.
- Integrated refrigerant detection and evacuation system in ecoGEO+ B/C 2-10 PRO and ecoGEO+ B/C 4-16 PRO models, not required in ecoGEO+ B/C 1-6 PRO models.

## Operational chart

ecoGEO+ B/C 1-6 PRO & AU6

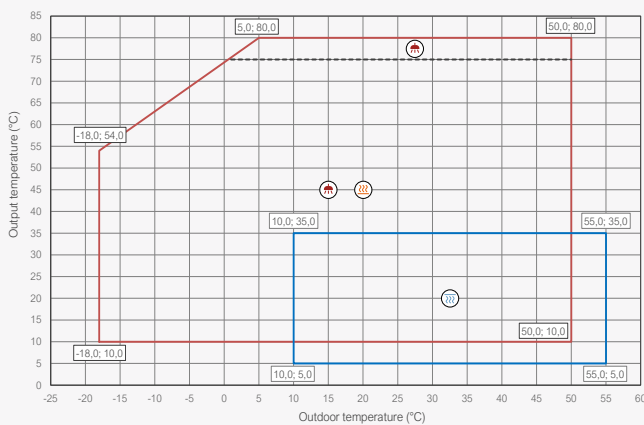

ecoGEO+ B/C 2-10 PRO & AU12 | ecoGEO+ B/C 4-16 PRO & AU22

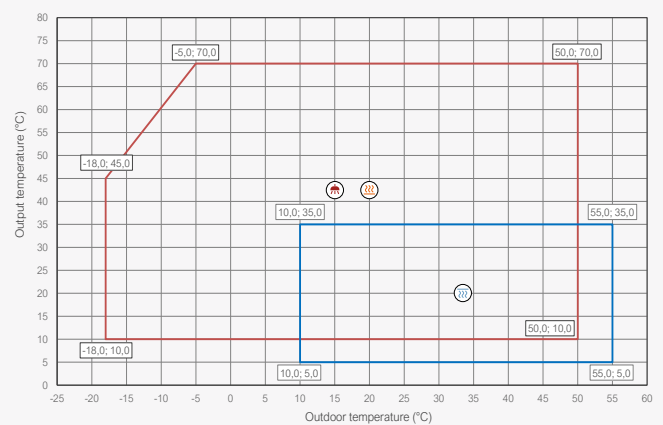

# ecoGEO<sup>+</sup> B/C 1-6 PRO & AU6

Brine to water heat pumps with Inverter technology, natural R290 refrigerant and air source collection



SPECIFICATIONS ecoGEO+ Basic / Compact PRO & AU			ecoGEO+ 1-6 PRO & AU6		
			B2 / C2	B4 / C4	
APPLICATION	Place of installation	-	ecoGEO+ : indoor / AU : outdoor		
	<sup>(1)</sup> Collection system	-	Air source		
	DHW, Heating and Pool heating	-	■		
	Integrated active cooling	-	-	■	
PERFORMANCE	Compressor modulation range	%	12.5 - 100		
	<sup>(2)</sup> Heating power output / COP A7W35	kW / -	0.5 - 5.6 / 4.0		
	<sup>(2)</sup> Heating power output / COP A7W55	kW / -	0.8 - 5.3 / 2.7		
	<sup>(2)</sup> Cooling power output / EER A35W7	kW / -	-	0.8 - 5.0 / 3.5	
	<sup>(5)</sup> Max. DHW temperature without / with support	°C	70 / 80		
	<sup>(6)</sup> Maximum indoor / outdoor noise power level (LWA)	dB (A)	44 / 54		
	Energy label / η <sub>s</sub> / SCOP W35 average clim. with control	-	A++ / 174% / 4.42		
	Energy label / η <sub>s</sub> / SCOP W55 average clim. with control	-	A++ / 136% / 3.48		
OPERATION LIMITS	Distribution / Set heating outlet temperature range	°C	10 - 75 / 20 - 75		
	Distribution / Set cooling outlet temperature range	°C	-	5 - 35 / 7 - 30	
	Outdoor temperature range	°C	-18 - 50		
	Minimum / Maximum refrigerant circuit pressure	bar	1.0 / 32.0		
	Production circuit pressure range	bar	0,5 - 3,0 (0,7) / 0,5 - 3,0 (1,5)		
	DHW tank capacity / maximum pressure	l / bar	165 / 8.0 (ecoGEO+ C)		
	R290 refrigerant load (GWP: 3)	kg	0.15		
WORKING FLUIDS	Compressor oil type / load	kg	PZ46M / 0.30		
	Primary circ. flow rate (Pmax, A7W35) ΔT 3°C / ΔT 5°C	m³/h	1.5 / 0.9		
	Secondary circ. flow rate (Pmax, A7W35) ΔT 5°C / ΔT 7°C	m³/h	1.0 / 0.7		
	Min. water volume for defrosting (35°C, ΔT 5°C)	l	80.0		
	Nominal air flow rate	m³/h	2721		
	CONTROL ELECTRICAL DATA	<sup>(8)</sup> 1/N/PE 230 V / 50-60 Hz	-	■	
		<sup>(9)</sup> Recommended external protection	-	-	
Transformer primary circuit fuse		A	0.5		
Transformer secondary circuit fuse		A	2.5		
HEAT PUMP ELECTRICAL DATA: SINGLE-PHASE VERSION	<sup>(8)</sup> 1/N/PE 230 V / 50-60 Hz	-	■		
	<sup>(9)</sup> Recommended external protection	-	C16A		
	<sup>(2)</sup> Maximum consumption A7W35	kW / A	1.6 / 6.8		
	<sup>(2)</sup> Maximum consumption A7W55	kW / A	2.0 / 8.6		
	<sup>(7)</sup> Minimum / Maximum starting current	A	0.6 / 1.8		
	Correction of cos φ	-	0.96 / 1		
DIMENSIONS & WEIGHT	Height x width x depth	mm	ecoGEO+ B: 1051x559x606 / ecoGEO+ C: 1943x609x724 & AU6: 670x790x500		
	Empty weight (without packaging)	kg	ecoGEO+ B: 133 / ecoGEO+ C: 194 & AU6: 54		

- Air-to-water by means of a brine-to water heat pump combined with a hydraulic outdoor air unit.
- In compliance with EN 14511, including circulation pumps, fan and compressor driver consumptions.
- Production flow rate according to EN 14511.
- Considering a heat slope from 20 to 50 °C in absence of consumption.
- Considering support provided by an emergency electrical heater or HTR. Max. DHW temp. with HTR can be limited by the compressor discharge temp.
- In compliance with EN 12102.
- Starting current depends on the working conditions of the hydraulic circuits.
- The admissible voltage range for proper operation of the heat pump is ±10%.
- Maximum consumption can vary significantly according to working conditions, or if the compressor's operation range is restricted. Consult the technical service manual for more information.
- Certification in process.

## Dimensions and hydraulic connections

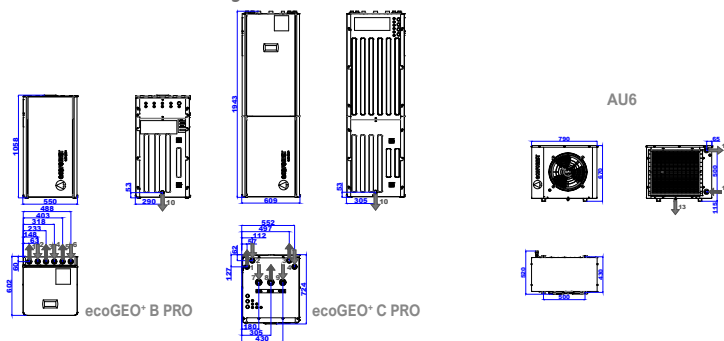

- Heating/Cooling outlet 1" M
- Heating/Cooling inlet 1" M
- Brine outlet 1" M
- Brine inlet 1" M
- DHW system outlet 3/4" H
- DHW system inlet 1" M
- CW inlet 1" H
- DHW outlet 1" H
- DHW recirc. inlet 3/4" H
- Drain 16mm
- AU source inlet 1" M
- AU source outlet 1" M
- AU drain 16mm

## Available pressure drop

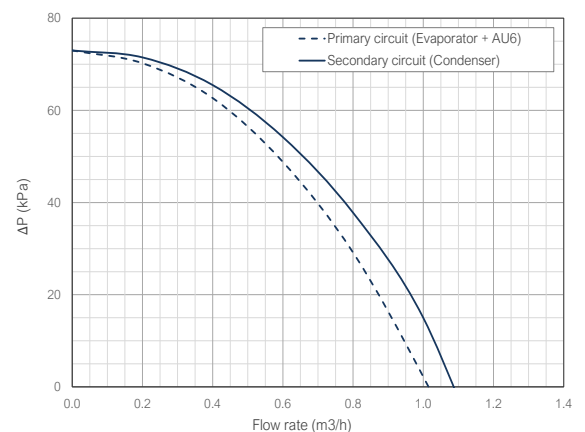

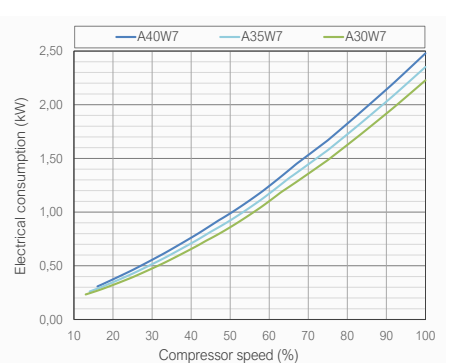
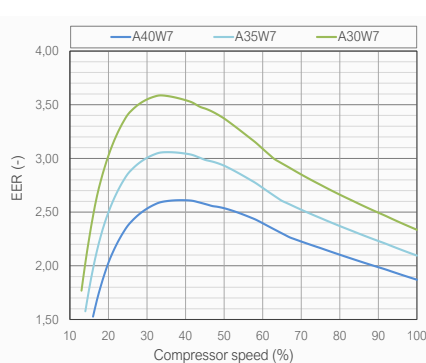
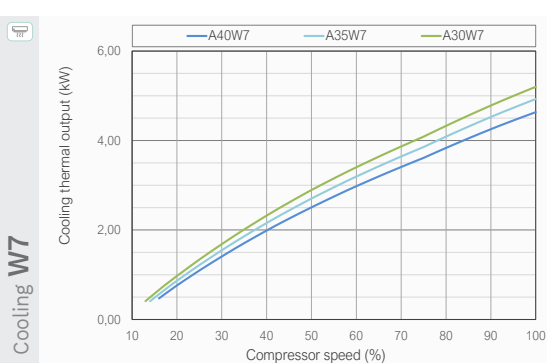
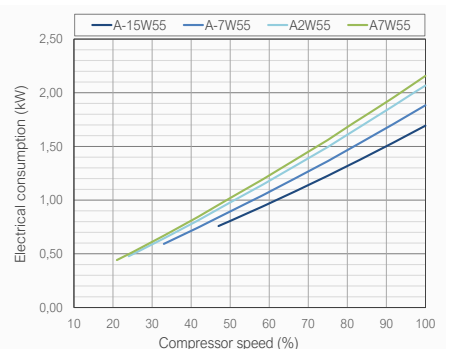
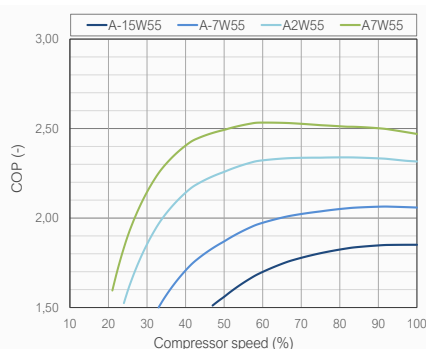
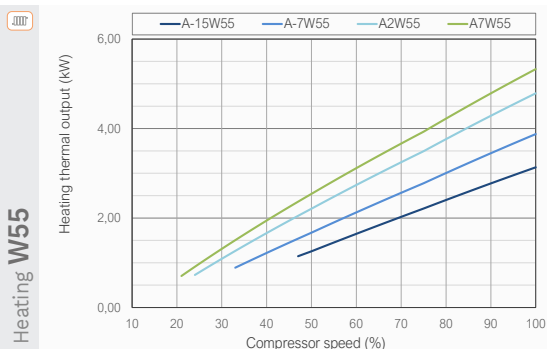
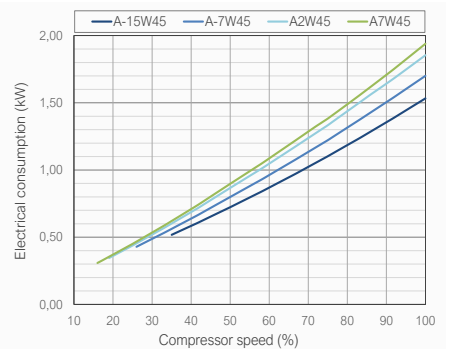
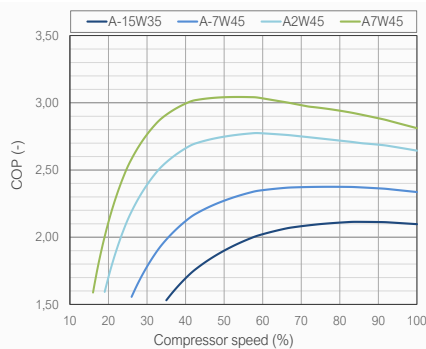
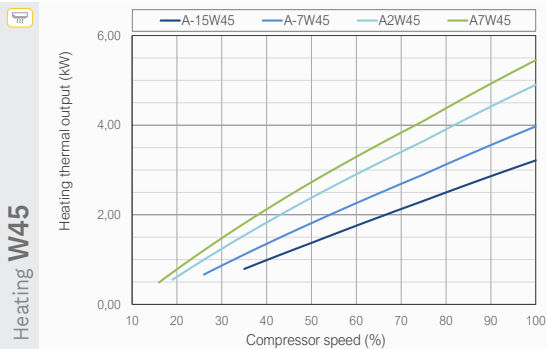
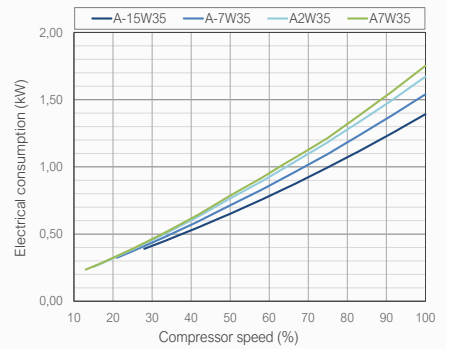
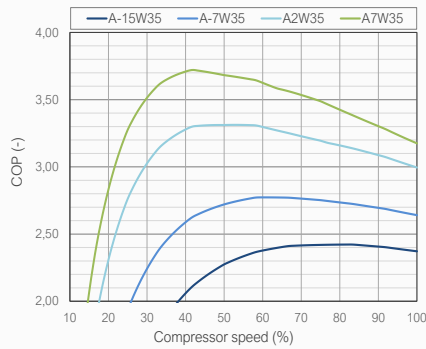
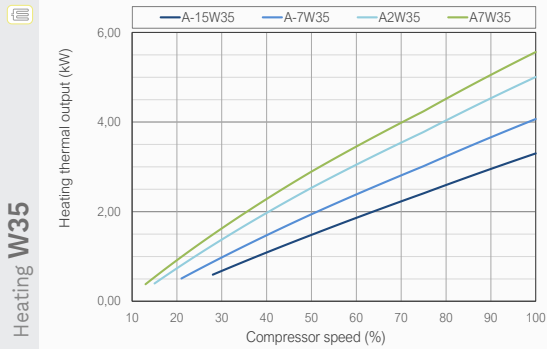

## Thermal power - Outdoor temperature

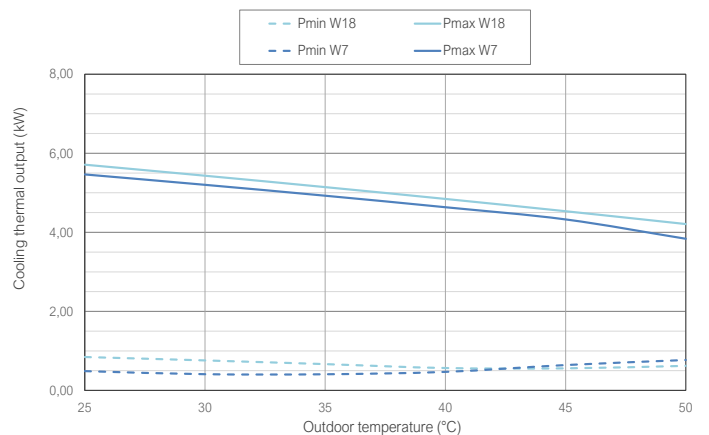
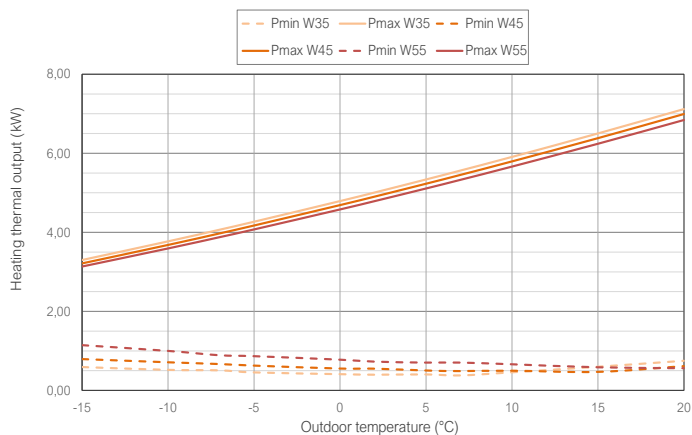

# ecoGEO<sup>+</sup> B/C 2-10 PRO & AU12

Brine to water heat pumps with Inverter technology, natural R290 refrigerant and air source collection



SPECIFICATIONS ecoGEO+ Basic / Compact PRO & AU			ecoGEO+ 2-10 PRO & AU12	
			B2 / C2	B4 / C4
APPLICATION	Place of installation	-	ecoGEO+ : indoor / AU : outdoor	
	<sup>(1)</sup> Collection system	-	Air source	
	DHW, Heating and Pool heating	-	■	
	Integrated active cooling	-	-	■
PERFORMANCE	Compressor modulation range	%	17 - 100	
	<sup>(2)</sup> Heating power output / COP A7W35	kW / -	2.1 - 10.5 / 4.6	
	<sup>(2)</sup> Heating power output / COP A7W55	kW / -	2.8 - 9.5 / 2.8	
	<sup>(2)</sup> Cooling power output / EER A35W7	kW / -	-	1.7 - 7.3 / 3.0
	<sup>(5)</sup> Max. DHW temperature without / with support	°C	70 / 80	
	<sup>(6)</sup> Maximum indoor / outdoor noise power level (LWA)	dB (A)	42 / 55	
	Energy label / ηs / SCOP W35 average clim. with control	-	A++ / 167% / 4.25	
OPERATION LIMITS	Energy label / ηs / SCOP W55 average clim. with control	-	-	
	Distribution / Set heating outlet temperature range	°C	10 - 70 / 20 - 70	
	Distribution / Set cooling outlet temperature range	°C	-	5 - 35 / 7 - 30
	Outdoor temperature range	°C	-15 - 50	
	Minimum / Maximum refrigerant circuit pressure	bar	1.0 / 32.0	
	Production circuit pressure range	bar	0,5 - 3,0 (0,7) / 0,5 - 3,0 (1,5)	
	DHW tank capacity / maximum pressure	l / bar	165 / 8,0 (ecoGEO+ C)	
WORKING FLUIDS	R290 refrigerant load (GWP: 3)	kg	0.60	
	Compressor oil type / load	kg	HXL4467 / 0.74	
	Primary circ. flow rate (Pmax, A7W35) ΔT 3°C / ΔT 5°C	m³/h	2.5 / 1.5	
	Secondary circ. flow rate (Pmax, A7W35) ΔT 5°C / ΔT 7°C	m³/h	1.8 / 1.3	
	Min. water volume for defrosting (35°C, ΔT 5°C)	l	150.0	
	Nominal air flow rate	m³/h	3309	
CONTROL ELECTRICAL DATA	<sup>(8)</sup> 1/N/PE 230 V / 50-60 Hz	-	■	
	<sup>(9)</sup> Recommended external protection	-	C16A	
	Transformer primary circuit fuse	A	0.5	
	Transformer secondary circuit fuse	A	2.5	
HEAT PUMP ELECTRICAL DATA: SINGLE-PHASE VERSION	<sup>(8)</sup> 1/N/PE 230 V / 50-60 Hz	-	■	
	<sup>(9)</sup> Recommended external protection	-	C25A	
	<sup>(2)</sup> Maximum consumption A7W35	kW / A	3.0 / 13.1	
	<sup>(2)</sup> Maximum consumption A7W55	kW / A	3.9 / 16.9	
	<sup>(7)</sup> Minimum / Maximum starting current	A	2.0 / 8.0	
	Correction of cos Ø	-	0.96 / 1	
HEAT PUMP ELECTRICAL DATA: THREE-PHASE VERSION	<sup>(8)</sup> 3/N/PE 400 V / 50-60 Hz	-	■	
	<sup>(9)</sup> Recommended external protection	-	C16A	
	<sup>(2)</sup> Maximum consumption A7W35	kW / A	3.0 / 4.3	
	<sup>(2)</sup> Maximum consumption A7W55	kW / A	3.9 / 5.6	
	<sup>(7)</sup> Minimum / Maximum starting current	A	0.7 / 2.6	
DIMENSIONS & WEIGHT	Height x width x depth	mm	ecoGEO+ B: 1051x609x716 / ecoGEO+ C: 1943x609x724 & AU12: 900x1800x600	
	Empty weight (without packaging)	kg	ecoGEO+ B: 205 / ecoGEO+ C: 270 & AU12: 175	

- Air-to-water by means of a brine-to-water heat pump combined with a hydraulic outdoor air unit.
- In compliance with EN 14511, including circulation pumps, fan and compressor driver consumptions.
- Production flow rate according to EN 14511.
- Considering a heat slope from 20 to 50 °C in absence of consumption.
- Considering support provided by an emergency electrical heater or HTR. Max. DHW temp. with HTR can be limited by the compressor discharge temp.
- In compliance with EN 12102.
- Starting current depends on the working conditions of the hydraulic circuits.
- The admissible voltage range for proper operation of the heat pump is ±10%.
- Maximum consumption can vary significantly according to working conditions, or if the compressor's operation range is restricted. Consult the technical service manual for more information.
- Certification in process.

## Dimensions and hydraulic connections

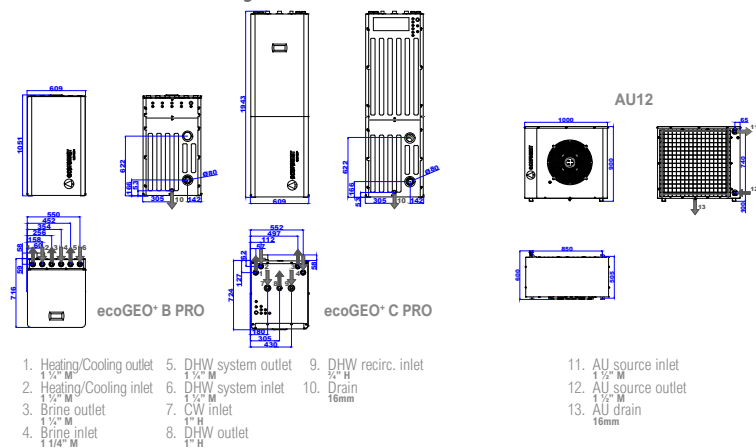

## Available pressure drop

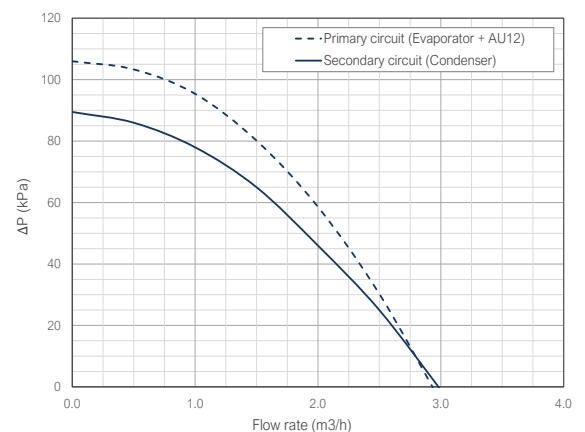

Heating W35

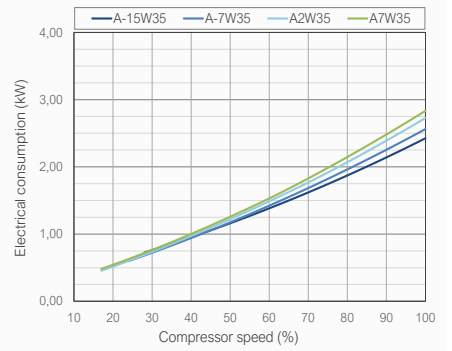
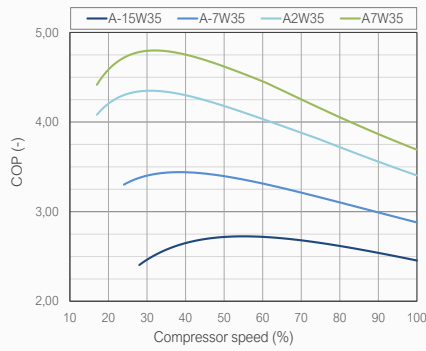
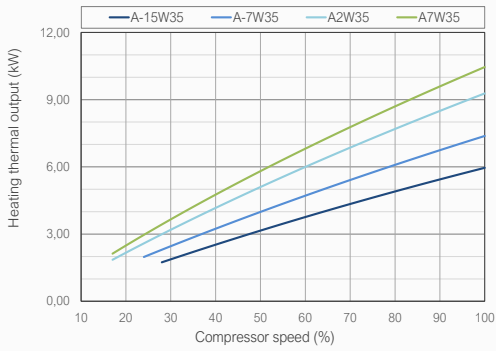

Heating W45

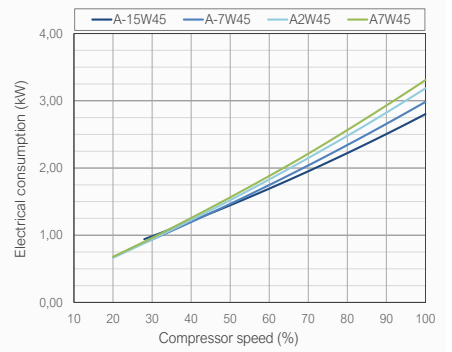
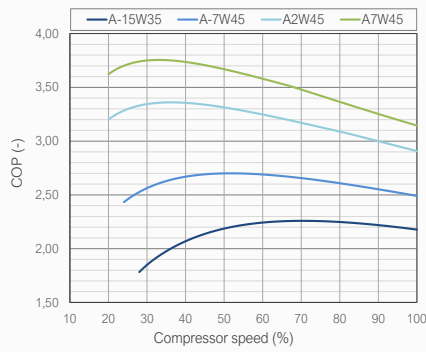
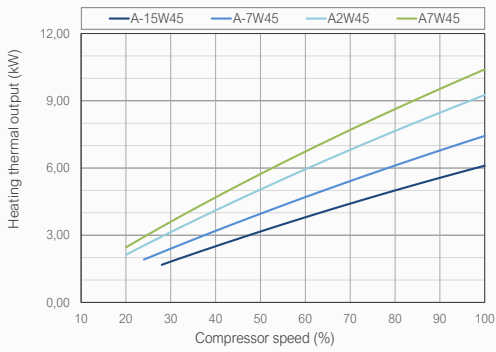

Heating W55

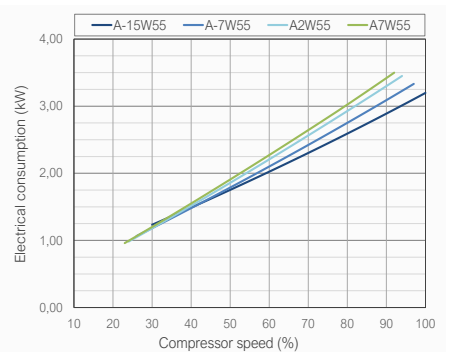
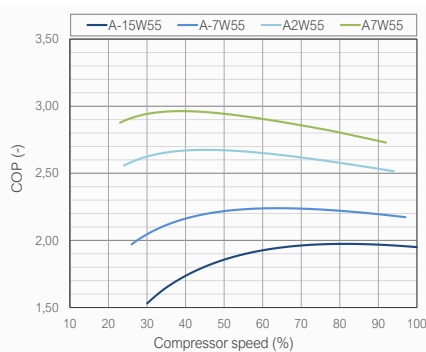
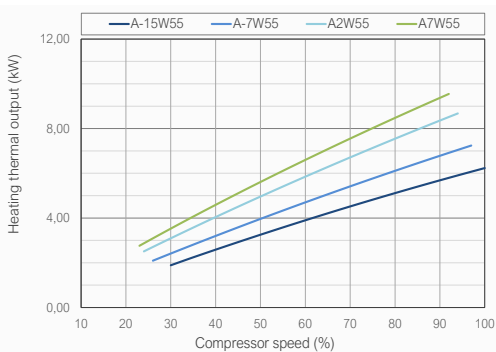

Cooling W7

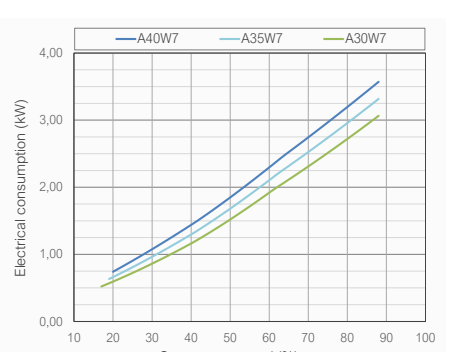
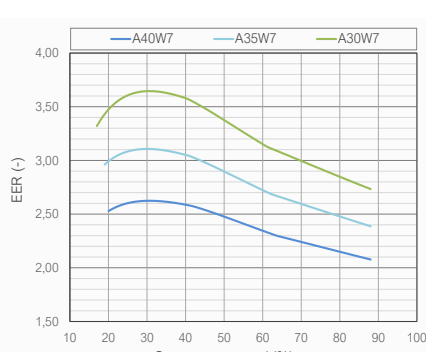
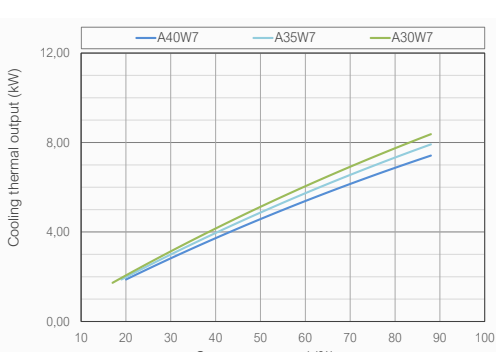

Thermal power - Outdoor temperature

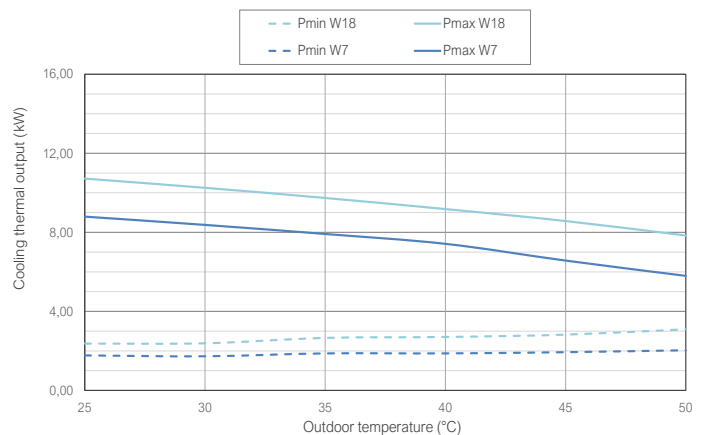
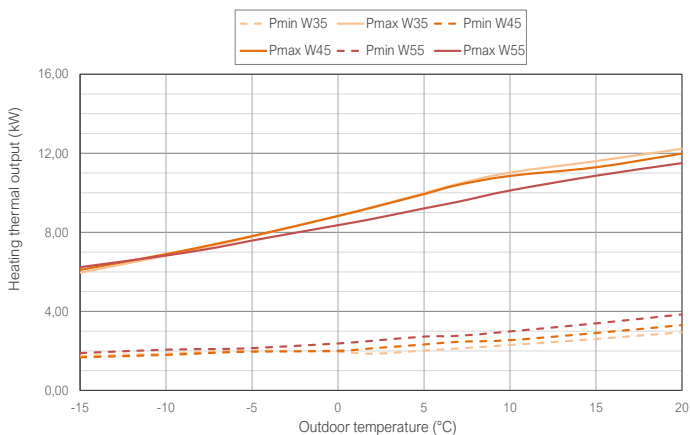

# ecoGEO<sup>+</sup> B/C 4-16 PRO & AU22

Brine to water heat pumps with Inverter technology, natural R290 refrigerant and air source collection



SPECIFICATIONS ecoGEO+ Basic / Compact PRO & AU			ecoGEO+ 4-16 PRO & AU22	
			B2 / C2	B4 / C4
APPLICATION	Place of installation	-	ecoGEO+ : indoor / AU : outdoor	
	<sup>(1)</sup> Collection system	-	Air source	
	DHW, Heating and Pool heating	-	■	
	Integrated active cooling	-	■	
PERFORMANCE	Compressor modulation range	%	17 - 100	
	<sup>(2)</sup> Heating power output / COP A7W35	kW / -	3.1 - 16.7 / 5.0	
	<sup>(2)</sup> Heating power output / COP A7W55	kW / -	4.0 - 15.0 / 3.3	
	<sup>(2)</sup> Cooling power output / EER A35W7	kW / -	-	
	<sup>(6)</sup> Max. DHW temperature without / with support	°C	70 / 80	
	<sup>(6)</sup> Maximum indoor / outdoor noise power level (LWA)	dB (A)	42 / 55	
	Energy label / ηs / SCOP W35 average clim. with control	-	A+++ / 189% / 4.80	
Energy label / ηs / SCOP W55 average clim. with control	-	-		
OPERATION LIMITS	Distribution / Set heating outlet temperature range	°C	10 - 70 / 20 - 70	
	Distribution / Set cooling outlet temperature range	°C	-	
	Outdoor temperature range	°C	-15 - 50	
	Minimum / Maximum refrigerant circuit pressure	bar	1.0 / 32.0	
	Production circuit pressure range	bar	0,5 - 3,0 (0,7) / 0,5 - 3,0 (1,5)	
	DHW tank capacity / maximum pressure	l / bar	165 / 8.0 (ecoGEO+ C)	
WORKING FLUIDS	R290 refrigerant load (GWP: 3)	kg	0.86	
	Compressor oil type / load	kg	HXL4467 / 1.18	
	Primary circ. flow rate (Pmax, A7W35) ΔT 3°C / ΔT 5°C	m³/h	4.1 / 2.4	
	Secondary circ. flow rate (Pmax, A7W35) ΔT 5°C / ΔT 7°C	m³/h	2.9 / 2.1	
	Min. water volume for defrosting (35°C, ΔT 5°C)	l	200.0	
	Nominal air flow rate	m³/h	6618	
CONTROL ELECTRICAL DATA	<sup>(8)</sup> 1/N/PE 230 V / 50-60 Hz	-	■	
	<sup>(9)</sup> Recommended external protection	-	C16A	
	Transformer primary circuit fuse	A	0.5	
	Transformer secondary circuit fuse	A	2.5	
HEAT PUMP ELECTRICAL DATA: SINGLE-PHASE VERSION	<sup>(8)</sup> 1/N/PE 230 V / 50-60 Hz	-	■	
	<sup>(9)</sup> Recommended external protection	-	C32A	
	<sup>(2)</sup> Maximum consumption A7W35	kW / A	4.7 / 20.6	
	<sup>(2)</sup> Maximum consumption A7W55	kW / A	6.1 / 26.4	
	<sup>(7)</sup> Minimum / Maximum starting current	A	2.6 / 12.5	
Correction of cos Ø	-	0.96 / 1		
HEAT PUMP ELECTRICAL DATA: THREE-PHASE VERSION	<sup>(8)</sup> 3/N/PE 400 V / 50-60 Hz	-	■	
	<sup>(9)</sup> Recommended external protection	-	C16A	
	<sup>(2)</sup> Maximum consumption A7W35	kW / A	4.7 / 6.8	
	<sup>(2)</sup> Maximum consumption A7W55	kW / A	6.1 / 8.8	
	<sup>(7)</sup> Minimum / Maximum starting current	A	0.9 / 4.2	
Correction of cos Ø	-	0.96 / 1		
DIMENSIONS & WEIGHT	Height x width x depth	mm	ecoGEO+ B: 1051x609x716 / ecoGEO+ C: 1943x609x724 & AU22: 900x1800x600	
	Empty weight (without packaging)	kg	ecoGEO+ B: 205 / ecoGEO+ C: 270 & AU22: 175	

- Air-to-water by means of a brine-to water heat pump combined with a hydraulic outdoor air unit.
- In compliance with EN 14511, including circulation pumps, fan and compressor driver consumptions.
- Production flow rate according to EN 14511.
- Considering a heat slope from 20 to 50 °C in absence of consumption.
- Considering support provided by an emergency electrical heater or HTR. Max. DHW temp. with HTR can be limited by the compressor discharge temp.
- In compliance with EN 12102.
- Starting current depends on the working conditions of the hydraulic circuits.
- The admissible voltage range for proper operation of the heat pump is ±10%.
- Maximum consumption can vary significantly according to working conditions, or if the compressor's operation range is restricted. Consult the technical service manual for more information.
- Certification in process.

## Dimensions and hydraulic connections

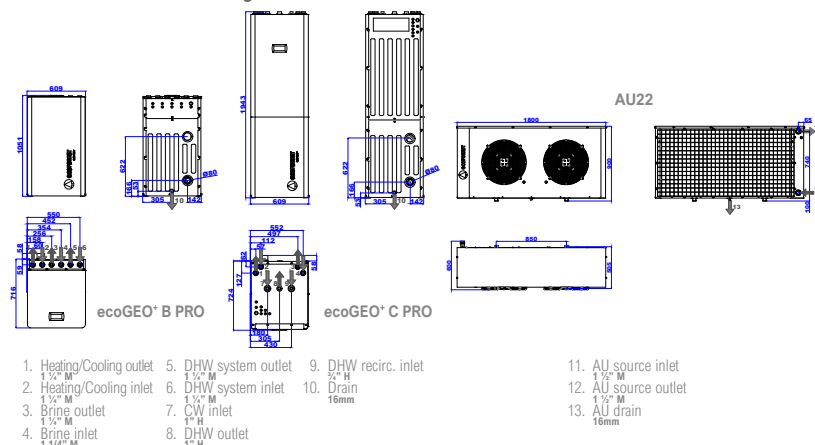

## Available pressure drop

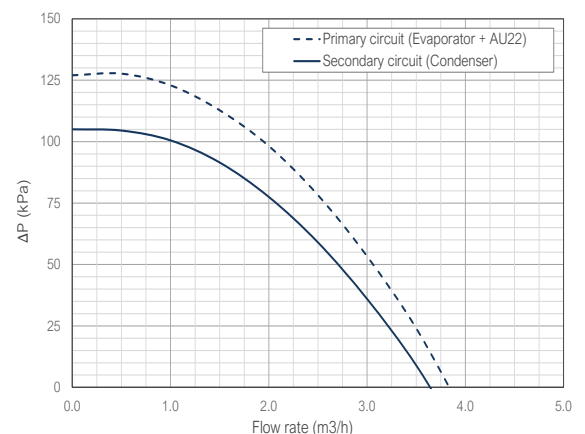

Heating W35

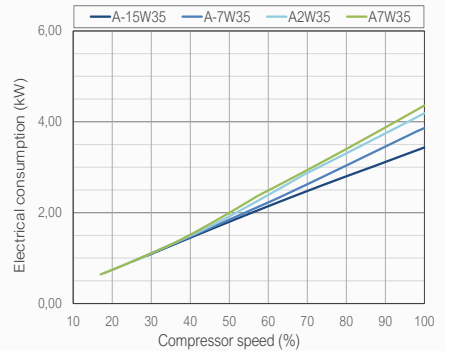
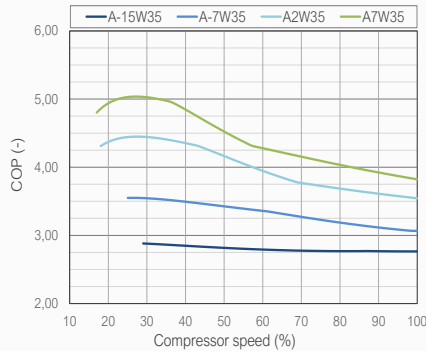
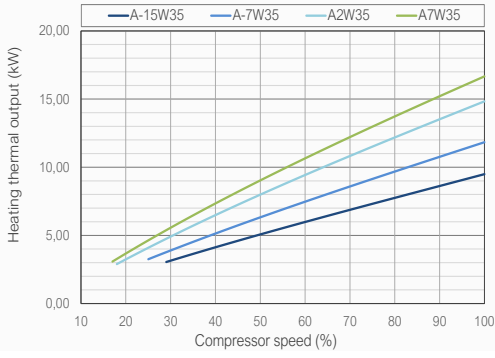

Heating W45

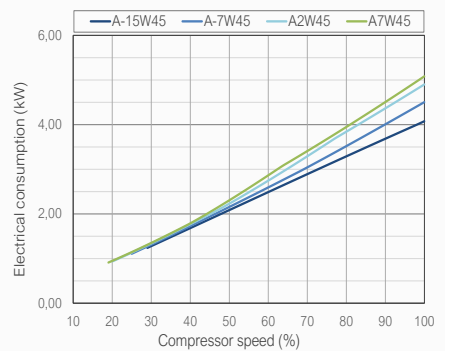
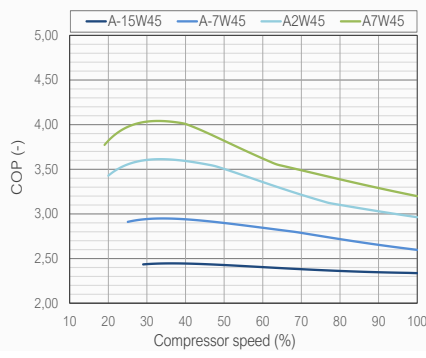
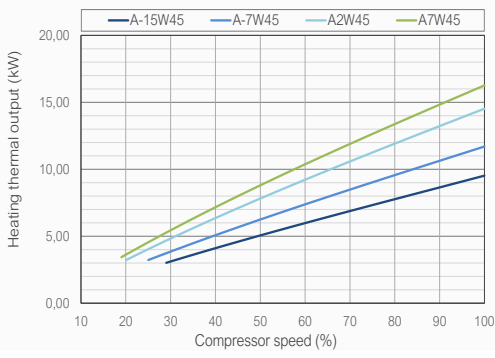

Heating W55

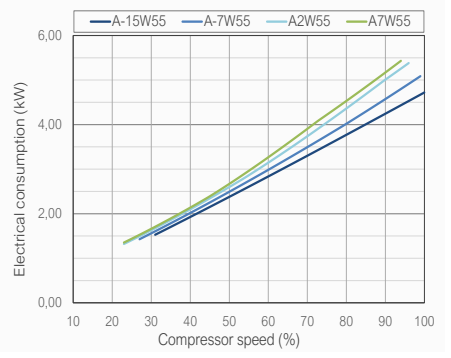
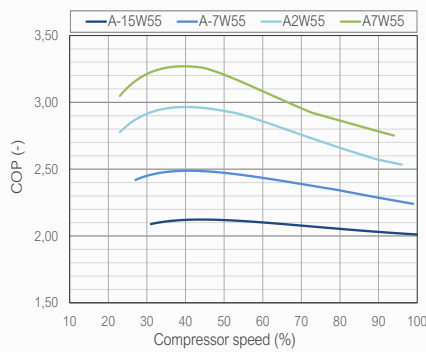
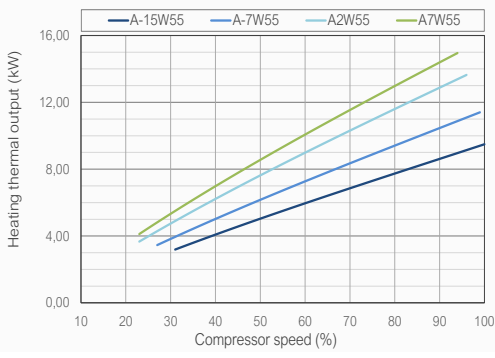

Cooling W7

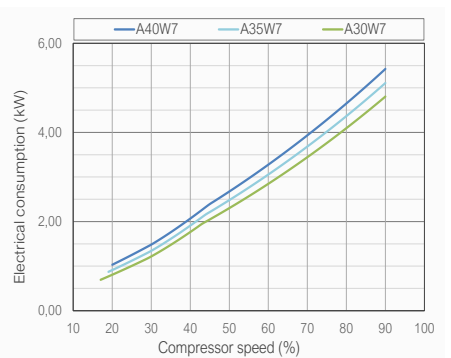
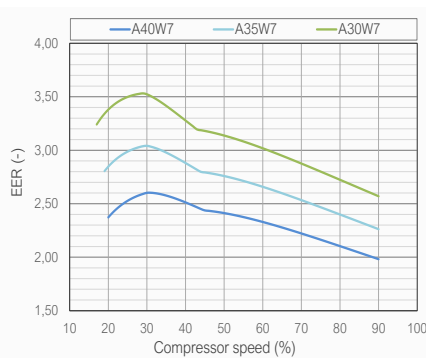
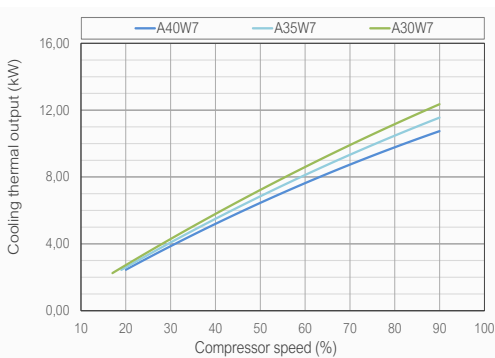

Thermal power - Outdoor temperature

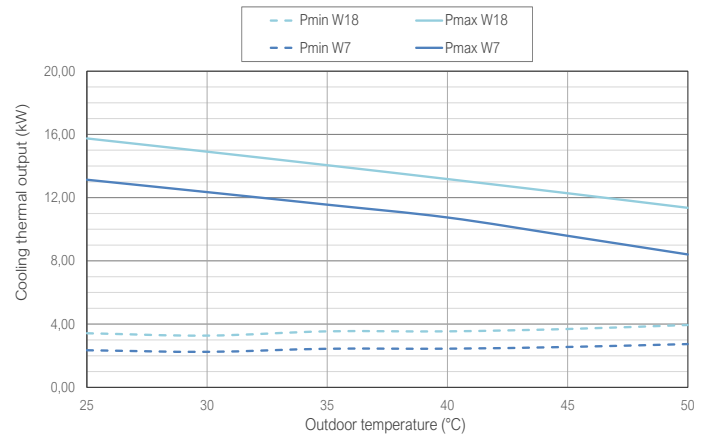
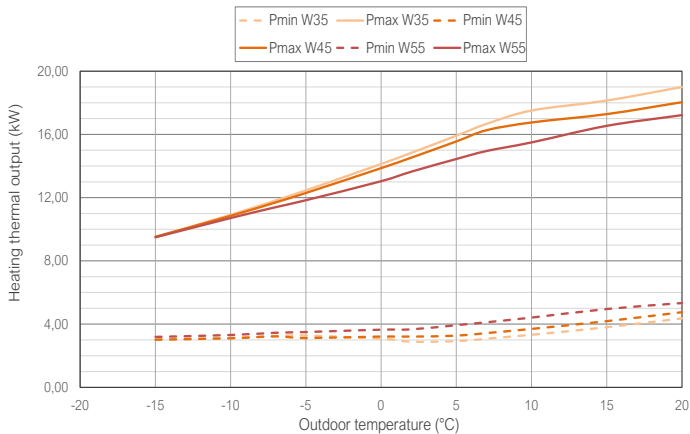



May 2026