



ecoGEO+ B/C & AU

R410A

1-9kW AU12/3-12kW AU12/5-22kW AU22

Air Source System Using Brine to
Water Heat Pumps with Dry Coolers



Characteristics

- Modulating thermal output control across a wide range (17%–100%), fan speed control (20%–100%), and modulating flow control in both source and production circuits (20%–100%).
- R410A refrigerant.
- Inverter technology.
- Compact design including source and production circulators, 8L and 12L expansion vessels for source and production respectively, source and production safety valves, and a 3-way valve for DHW.
- High Temperature Recovery (HTR) system for domestic hot water (DHW) production up to 70 °C without auxiliary support, and simultaneous production of DHW and heating/cooling.
- Integrated control of up to three different flow temperatures, two buffer tanks (heating and cooling), one DHW tank, one swimming pool, and time scheduling of DHW recirculation.
- Integrated management of modulating air source units in air source or hybrid air-ground source systems.
- Integrated control of external auxiliary backup systems on/off or modulating (electric heaters, boilers, etc.).
- Cascade management of up to three heat pumps.
- Exclusive defrost management.
- Active cooling via cycle inversion integrated in B4/C4 models.
- Models available in both single-phase and three-phase versions.
- Integrated photovoltaic hybridisation.
- Integrated energy meters for monitoring electrical consumption, thermal output (heating/cooling), and instantaneous as well as seasonal efficiency monthly and annual.

Operational chart

ecoGEO⁺ B/C 1-9 & AU12 | ecoGEO⁺ B/C 3-12 & AU12 | ecoGEO⁺ B/C 5-22 & AU22

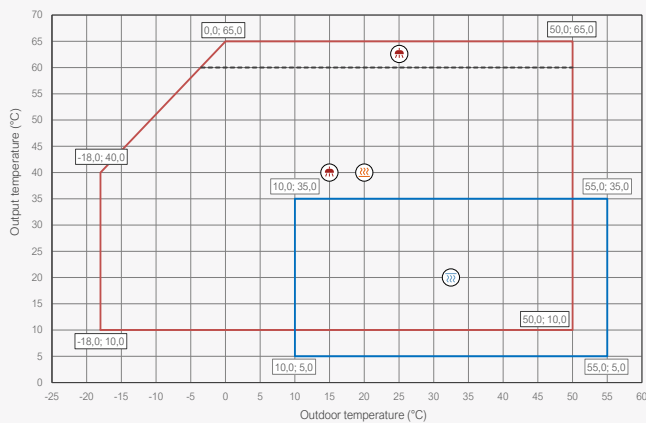

ecoGEO⁺ B/C 1-9 & AU12

Brine to water heat pumps with Inverter technology, R410A refrigerant and air source collection



SPECIFICATIONS ecoGEO+ Basic / Compact & AU			ecoGEO+ 1-9 & AU12	
			B2 / C2	B4 / C4
APPLICATION	Place of installation	-	ecoGEO+ : indoor / AU : outdoor	
	⁽¹⁾ Collection system	-	Air source	
	DHW, Heating and Pool heating	-	■	
	Integrated active cooling	-	-	■
PERFORMANCE	Compressor modulation range	%	12.5 - 100	
	⁽²⁾ Heating power output / COP A7W35	kW / -	1.7 - 11 / 5.0	
	⁽²⁾ Heating power output / COP A7W55	kW / -	3.3 - 10.4 / 3.0	
	⁽²⁾ Cooling power output / EER A35W7	kW / -	-	1.5 - 9.8 / 3.6
	⁽⁶⁾ Max. DHW temperature without / with support	°C	63 / 70	
	⁽⁶⁾ Maximum indoor / outdoor noise power level (LWA)	dB (A)	54 / 55	
	Energy label / ηs / SCOP W35 average clim. with control	-	A+++ / 194% / 4.91	
Energy label / ηs / SCOP W55 average clim. with control	-	A++ / 144% / 3.68		
OPERATION LIMITS	Distribution / Set heating outlet temperature range	°C	10 - 60 / 20 - 60	
	Distribution / Set cooling outlet temperature range	°C	-	5 - 35 / 7 - 30
	Outdoor temperature range	°C	-10 - 50	
	Minimum / Maximum refrigerant circuit pressure	bar	2.0 / 45.0	
	Production circuit pressure range	bar	0,5 - 3,0 (0,7) / 0,5 - 3,0 (1,5)	
	DHW tank capacity / maximum pressure	l / bar	165 / 8.0 (ecoGEO+ C)	
WORKING FLUIDS	R410A refrigerant load (GWP: 2088)	kg	0,80 / 0,85 (HTR)	1.00
	Compressor oil type / load	kg	POE / 0.74	
	Primary circ. flow rate (Pmax, A7W35) ΔT 3°C / ΔT 5°C	m³/h	2.7 / 1.6	
	Secondary circ. flow rate (Pmax, A7W35) ΔT 5°C / ΔT 7°C	m³/h	1.9 / 1.3	
	Min. water volume for defrosting (35°C, ΔT 5°C)	l	150.0	
	Nominal air flow rate	m³/h	3309	
	CONTROL ELECTRICAL DATA	⁽⁸⁾ 1/N/PE 230 V / 50-60 Hz	-	■
⁽⁹⁾ Recommended external protection		-	C16A	
Transformer primary circuit fuse		A	0.5	
Transformer secondary circuit fuse		A	2.5	
HEAT PUMP ELECTRICAL DATA: SINGLE-PHASE VERSION	⁽⁸⁾ 1/N/PE 230 V / 50-60 Hz	-	■	
	⁽⁹⁾ Recommended external protection	-	C25A	
	⁽²⁾ Maximum consumption A7W35	kW / A	2.7 / 11.8	
	⁽²⁾ Maximum consumption A7W55	kW / A	3.8 / 16.5	
	⁽⁷⁾ Minimum / Maximum starting current	A	1.5 / 5.8	
	Correction of cos Ø	-	0.96 / 1	
HEAT PUMP ELECTRICAL DATA: THREE-PHASE VERSION	⁽⁸⁾ 3/N/PE 400 V / 50-60 Hz	-	■	
	⁽⁹⁾ Recommended external protection	-	C10A	
	⁽²⁾ Maximum consumption A7W35	kW / A	2.7 / 4.0	
	⁽²⁾ Maximum consumption A7W55	kW / A	3.8 / 5.5	
	⁽⁷⁾ Minimum / Maximum starting current	A	0.5 / 1.9	
Correction of cos Ø	-	0.96 / 1		
DIMENSIONS & WEIGHT	Height x width x depth	mm	ecoGEO+ B: 1058x600x710 / ecoGEO+ C: 1845x600x720 & AU12: 900x1000x600	
	Empty weight (without packaging)	kg	ecoGEO+ B: 192 / ecoGEO+ C: 253 & AU12: 92	

- Air-to-water by means of a brine-to water heat pump combined with a hydraulic outdoor air unit.
- In compliance with EN 14511, including circulation pumps, fan and compressor driver consumptions.
- Production flow rate according to EN 14511.
- Considering a heat slope from 20 to 50 °C in absence of consumption.
- Considering support provided by an emergency electrical heater or HTR. Max. DHW temp. with HTR can be limited by the compressor discharge temp.
- In compliance with EN 12102.
- Starting current depends on the working conditions of the hydraulic circuits.
- The admissible voltage range for proper operation of the heat pump is ±10%.
- Maximum consumption can vary significantly according to working conditions, or if the compressor's operation range is restricted. Consult the technical service manual for more information.
- Certification in process.

Dimensions and hydraulic connections

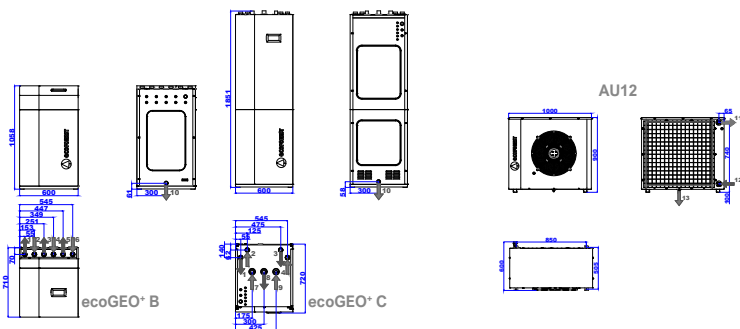

- Heating/Cooling outlet 1 1/2" M
- Heating/Cooling inlet 1 1/2" M
- Brine outlet 1 1/2" M
- Brine inlet 1 1/4" M
- DHW system outlet 1 1/2" M
- DHW system inlet 1 1/2" M
- CW inlet 1" H
- DHW outlet 1" H
- DHW recirc. inlet 1 1/2" M
- Drain 16mm
- AU source inlet 1 1/2" M
- AU source outlet 1 1/2" M
- AU drain 16mm

Available pressure drop

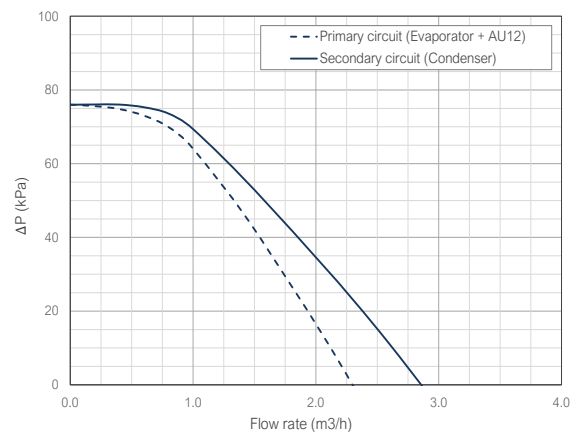

Heating W35

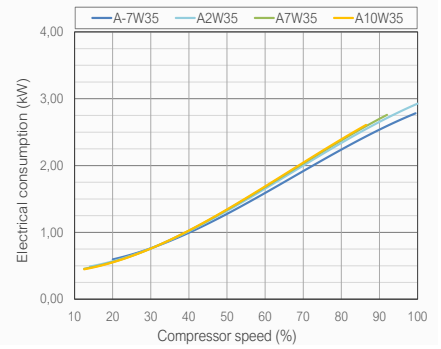
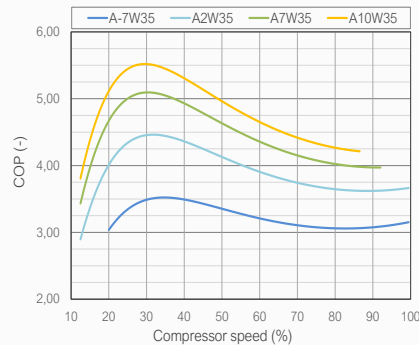
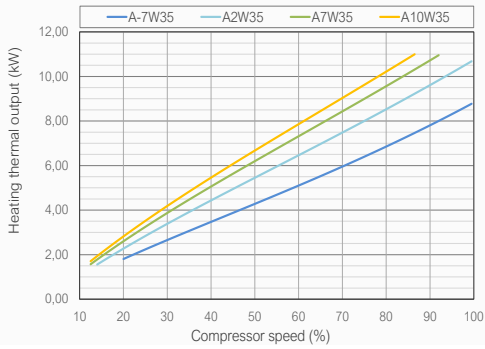

Heating W45

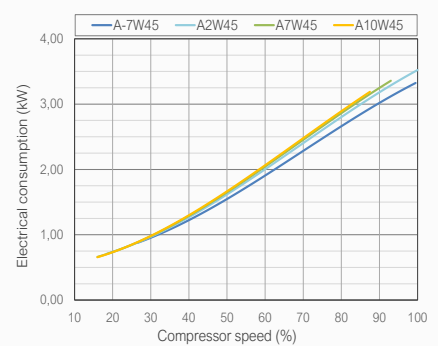
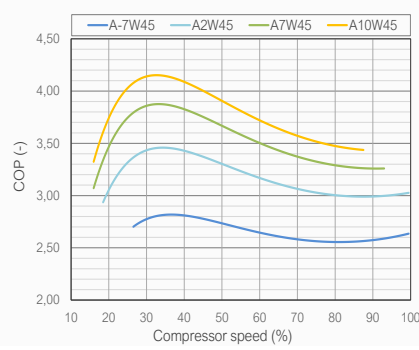
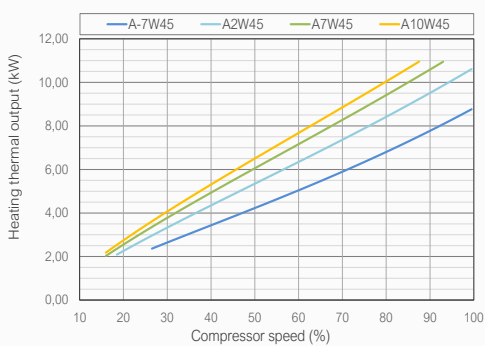

Heating W55

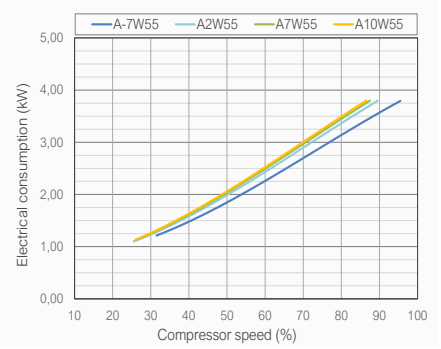
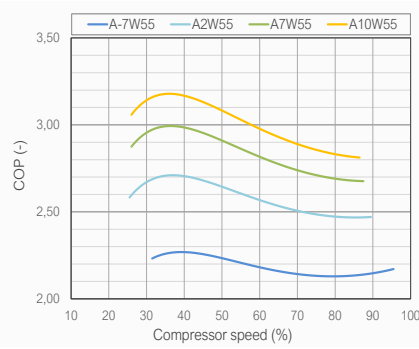
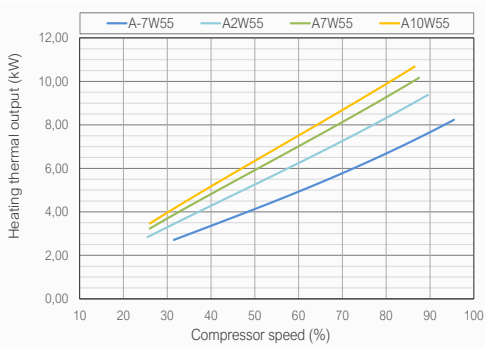

Cooling W7

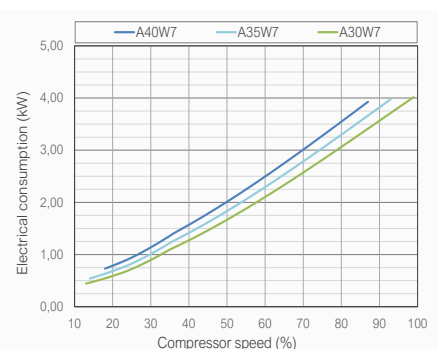
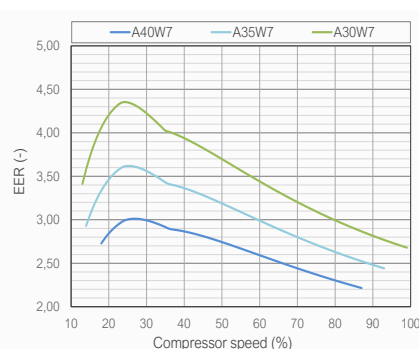
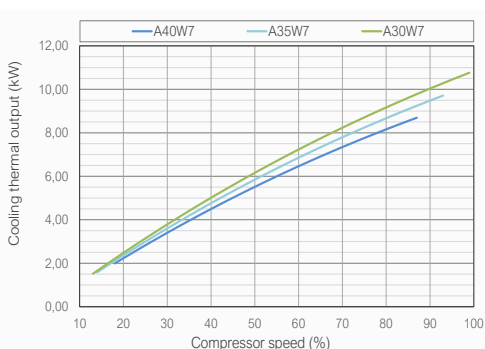

Thermal power - Outdoor temperature

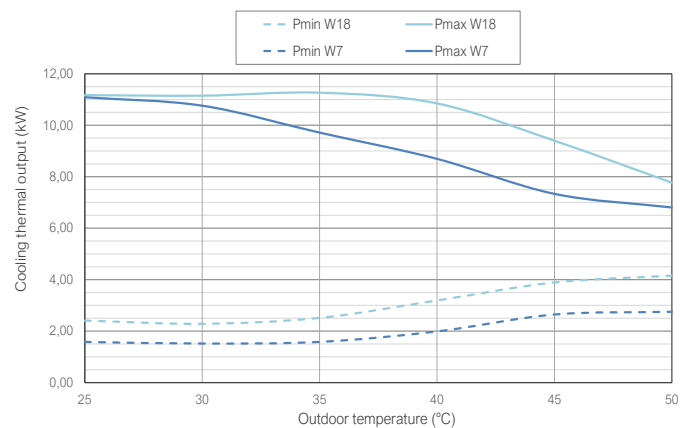
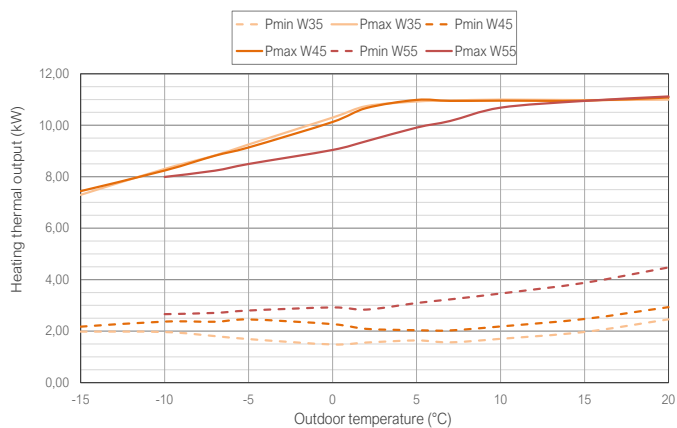

ecoGEO⁺ B/C 3-12 & AU12

Brine to water heat pumps with Inverter technology, R410A refrigerant and air source collection



SPECIFICATIONS ecoGEO+ Basic / Compact & AU			ecoGEO+ 3-12 & AU12	
			B2 / C2	B4 / C4
APPLICATION	Place of installation	-	ecoGEO+ : indoor / AU : outdoor	
	⁽¹⁾ Collection system	-	Air source	
	DHW, Heating and Pool heating	-	■	
	Integrated active cooling	-	-	■
PERFORMANCE	Compressor modulation range	%	12.5 - 100	
	⁽²⁾ Heating power output / COP A7W35	kW / -	2.5 - 15.3 / 5.0	
	⁽²⁾ Heating power output / COP A7W55	kW / -	4.4 - 13.6 / 3.1	
	⁽²⁾ Cooling power output / EER A35W7	kW / -	-	2.4 - 11.7 / 3.4
	⁽⁵⁾ Max. DHW temperature without / with support	°C	63 / 70	
	⁽⁶⁾ Maximum indoor / outdoor noise power level (LWA)	dB (A)	54 / 55	
	Energy label / η _s / SCOP W35 average clim. with control	-	A+++ / 194% / 4.92	
Energy label / η _s / SCOP W55 average clim. with control	-	A++ / 149% / 3.79		
OPERATION LIMITS	Distribution / Set heating outlet temperature range	°C	10 - 60 / 20 - 60	
	Distribution / Set cooling outlet temperature range	°C	-	5 - 35 / 7 - 30
	Outdoor temperature range	°C	-10 - 50	
	Minimum / Maximum refrigerant circuit pressure	bar	2.0 / 45.0	
	Production circuit pressure range	bar	0,5 - 3,0 (0,7) / 0,5 - 3,0 (1,5)	
	DHW tank capacity / maximum pressure	l / bar	165 / 8.0 (ecoGEO+ C)	
WORKING FLUIDS	R410A refrigerant load (GWP: 2088)	kg	0,90 / 1,00 (HTR)	1.00
	Compressor oil type / load	kg	POE / 0.74	
	Primary circ. flow rate (Pmax, A7W35) ΔT 3°C / ΔT 5°C	m³/h	3.4 / 2.1	
	Secondary circ. flow rate (Pmax, A7W35) ΔT 5°C / ΔT 7°C	m³/h	2.5 / 1.8	
	Min. water volume for defrosting (35°C, ΔT 5°C)	l	150.0	
	Nominal air flow rate	m³/h	3309	
	CONTROL ELECTRICAL DATA	⁽⁸⁾ 1/N/PE 230 V / 50-60 Hz	-	■
⁽⁹⁾ Recommended external protection		-	C16A	
Transformer primary circuit fuse		A	0.5	
Transformer secondary circuit fuse		A	2.5	
HEAT PUMP ELECTRICAL DATA: SINGLE-PHASE VERSION	⁽⁸⁾ 1/N/PE 230 V / 50-60 Hz	-	■	
	⁽⁹⁾ Recommended external protection	-	C32A	
	⁽²⁾ Maximum consumption A7W35	kW / A	4.2 / 18.6	
	⁽²⁾ Maximum consumption A7W55	kW / A	5.0 / 21.7	
	⁽⁷⁾ Minimum / Maximum starting current	A	2.0 / 8.0	
	Correction of cos Ø	-	0.96 / 1	
HEAT PUMP ELECTRICAL DATA: THREE-PHASE VERSION	⁽⁸⁾ 3/N/PE 400 V / 50-60 Hz	-	■	
	⁽⁹⁾ Recommended external protection	-	C16A	
	⁽²⁾ Maximum consumption A7W35	kW / A	4.2 / 6.2	
	⁽²⁾ Maximum consumption A7W55	kW / A	5.0 / 7.2	
	⁽⁷⁾ Minimum / Maximum starting current	A	0.7 / 2.6	
Correction of cos Ø	-	0.96 / 1		
DIMENSIONS & WEIGHT	Height x width x depth	mm	ecoGEO+ B: 1058x600x710 / ecoGEO+ C: 1845x600x720 & AU12: 900x1000x600	
	Empty weight (without packaging)	kg	ecoGEO+ B: 193 / ecoGEO+ C: 254 & AU12: 92	

- Air-to-water by means of a brine-to water heat pump combined with a hydraulic outdoor air unit.
- In compliance with EN 14511, including circulation pumps, fan and compressor driver consumptions.
- Production flow rate according to EN 14511.
- Considering a heat slope from 20 to 50 °C in absence of consumption.
- Considering support provided by an emergency electrical heater or HTR. Max. DHW temp. with HTR can be limited by the compressor discharge temp.
- In compliance with EN 12102.
- Starting current depends on the working conditions of the hydraulic circuits.
- The admissible voltage range for proper operation of the heat pump is ±10%.
- Maximum consumption can vary significantly according to working conditions, or if the compressor's operation range is restricted. Consult the technical service manual for more information.
- Certification in process.

Dimensions and hydraulic connections

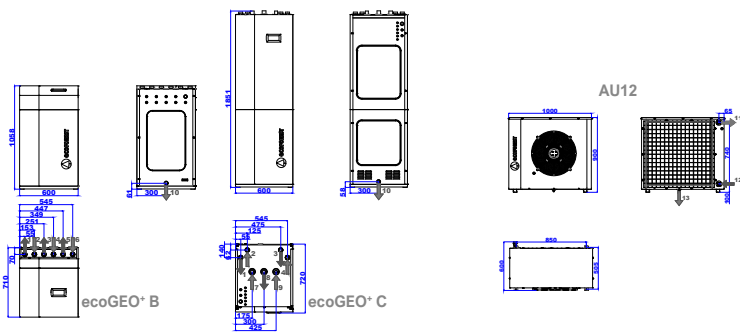

- Heating/Cooling outlet 1 1/2" M
- Heating/Cooling inlet 1 1/2" M
- Brine outlet 1 1/2" M
- Brine inlet 1 1/4" M
- DHW system outlet 1 1/2" M
- DHW system inlet 1 1/2" M
- CW inlet 1" H
- DHW outlet 1" H
- DHW recirc. inlet 9/2" H
- Drain 16mm
- AU source inlet 1 1/2" M
- AU source outlet 1 1/2" M
- AU drain 16mm

Available pressure drop

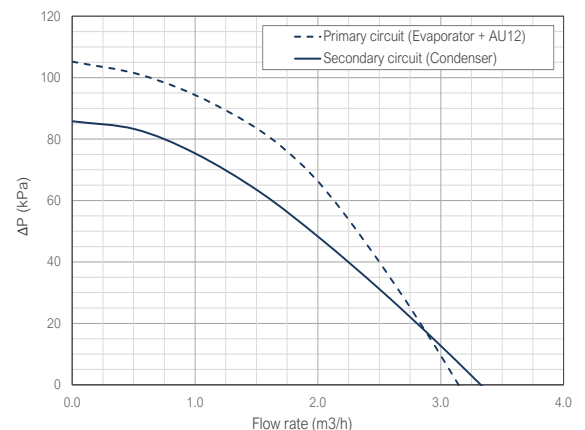



Heating W35

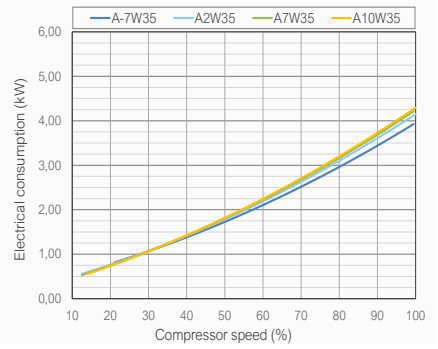
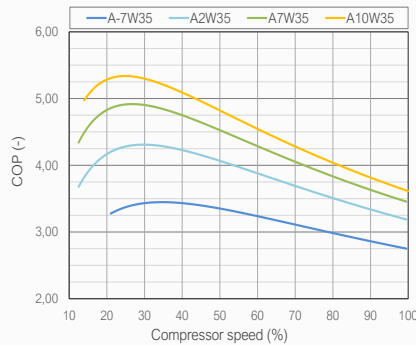
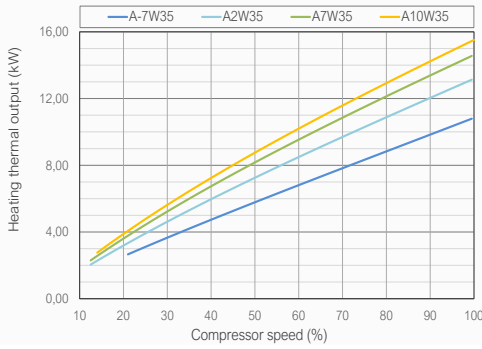

Heating W45

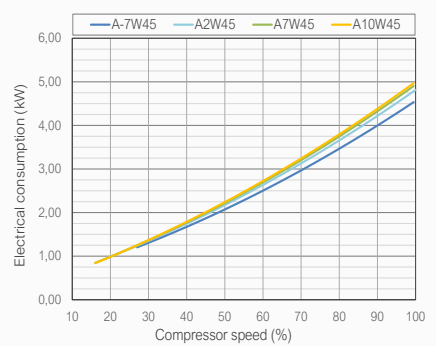
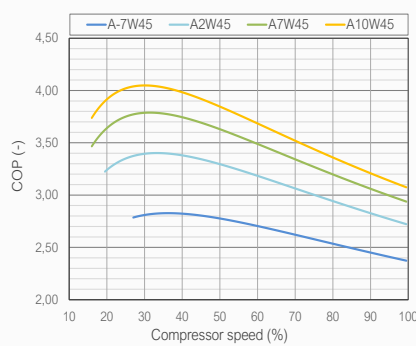
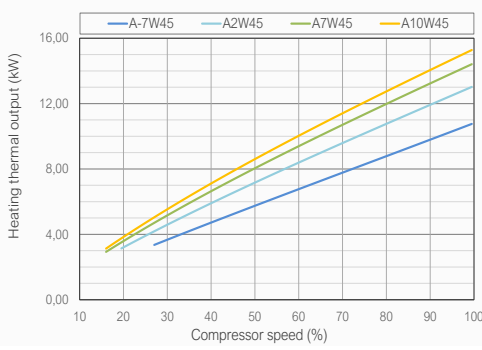

Heating W55

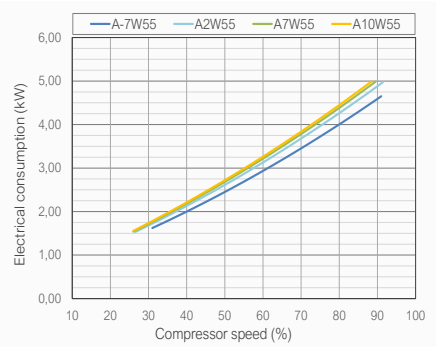
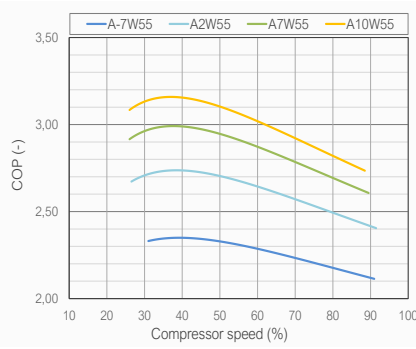
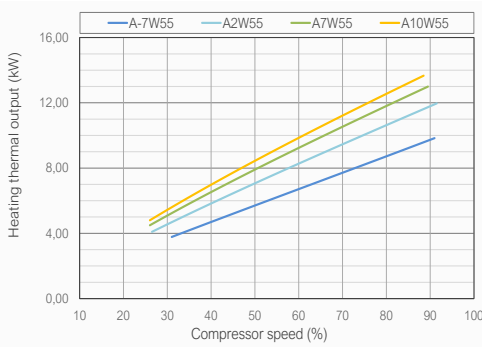

Cooling W7

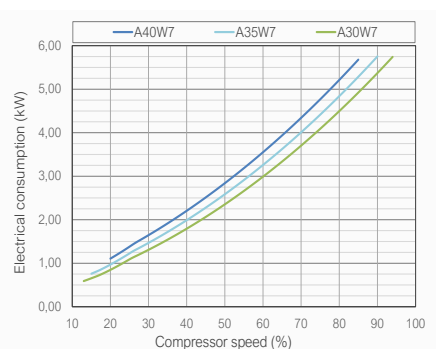
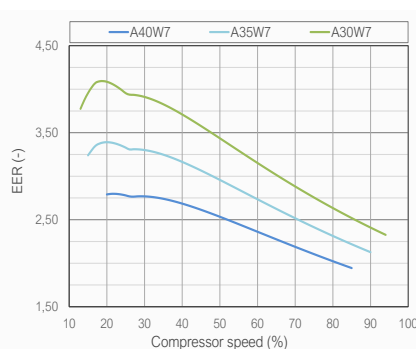
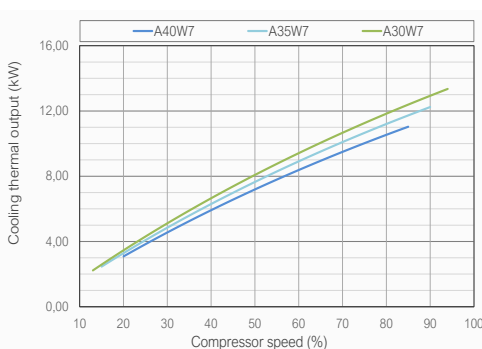

Thermal power - Outdoor temperature

--- Pmin W35 --- Pmax W35 --- Pmin W45
--- Pmax W45 --- Pmin W55 --- Pmax W55

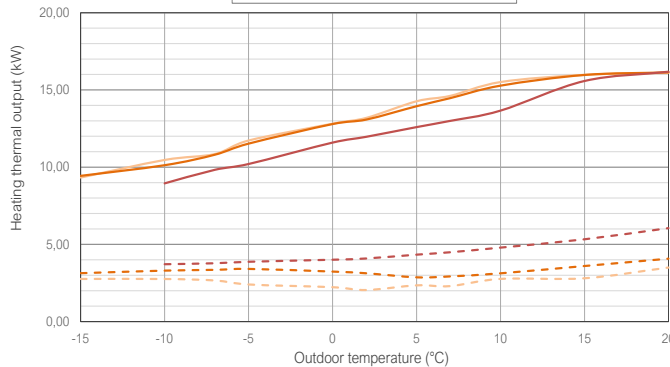

--- Pmin W18 --- Pmax W18
--- Pmin W7 --- Pmax W7

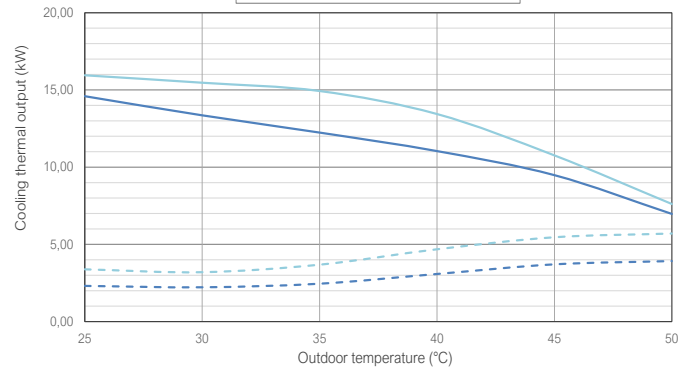

ecoGEO⁺ B/C 5-22 & AU22

Brine to water heat pumps with Inverter technology, R410A refrigerant and air source collection



SPECIFICATIONS ecoGEO+ Basic / Compact & AU			ecoGEO+ 5-22 & AU22	
			B2 / C2	B4 / C4
APPLICATION	Place of installation	-	ecoGEO+ : indoor / AU : outdoor	
	⁽¹⁾ Collection system	-	Air source	
	DHW, Heating and Pool heating	-	■	
	Integrated active cooling	-	-	■
PERFORMANCE	Compressor modulation range	%	15 - 100	
	⁽²⁾ Heating power output / COP A7W35	kW / -	4.6 - 21.3 / 5.1	
	⁽²⁾ Heating power output / COP A7W55	kW / -	5.6 - 16.7 / 3.1	
	⁽²⁾ Cooling power output / EER A35W7	kW / -	-	5.1 - 15.2 / 3.7
	⁽⁶⁾ Max. DHW temperature without / with support	°C	63 / 70	
	⁽⁶⁾ Maximum indoor / outdoor noise power level (LWA)	dB (A)	42 / 55	
	Energy label / η _s / SCOP W35 average clim. with control	-	A+++ / 195 % / 4.95	
	Energy label / η _s / SCOP W55 average clim. with control	-	A++ / 149 % / 3.80	
OPERATION LIMITS	Distribution / Set heating outlet temperature range	°C	10 - 60 / 20 - 60	
	Distribution / Set cooling outlet temperature range	°C	-	5 - 35 / 7 - 30
	Outdoor temperature range	°C	-10 - 50	
	Minimum / Maximum refrigerant circuit pressure	bar	2.0 / 45.0	
	Production circuit pressure range	bar	0,5 - 3,0 (0,7) / 0,5 - 3,0 (1,5)	
	DHW tank capacity / maximum pressure	l / bar	165 / 8.0 (ecoGEO+ C)	
	R410A refrigerant load (GWP: 2088)	kg	1.40	1.50
WORKING FLUIDS	Compressor oil type / load	kg	POE / 1.18	
	Primary circ. flow rate (Pmax, A7W35) ΔT 3°C / ΔT 5°C	m³/h	5.3 / 3.2	
	Secondary circ. flow rate (Pmax, A7W35) ΔT 5°C / ΔT 7°C	m³/h	3.8 / 2.7	
	Min. water volume for defrosting (35°C, ΔT 5°C)	l	200.0	
	Nominal air flow rate	m³/h	6618	
	CONTROL ELECTRICAL DATA	⁽⁸⁾ 1/N/PE 230 V / 50-60 Hz	-	■
⁽⁹⁾ Recommended external protection		-	C16A	
Transformer primary circuit fuse		A	0.5	
Transformer secondary circuit fuse		A	2.5	
HEAT PUMP ELECTRICAL DATA: SINGLE-PHASE VERSION	⁽⁸⁾ 1/N/PE 230 V / 50-60 Hz	-	■	
	⁽⁹⁾ Recommended external protection	-	C32A	
	⁽²⁾ Maximum consumption A7W35	kW / A	5.5 / 23.9	
	⁽²⁾ Maximum consumption A7W55	kW / A	5.5 / 23.9	
	⁽⁷⁾ Minimum / Maximum starting current	A	2.6 / 12.5	
	Correction of cos φ	-	0.96 / 1	
HEAT PUMP ELECTRICAL DATA: THREE-PHASE VERSION	⁽⁸⁾ 3/N/PE 400 V / 50-60 Hz	-	■	
	⁽⁹⁾ Recommended external protection	-	C16A	
	⁽²⁾ Maximum consumption A7W35	kW / A	6.0 / 8.7	
	⁽²⁾ Maximum consumption A7W55	kW / A	6.0 / 8.7	
	⁽⁷⁾ Minimum / Maximum starting current	A	0.9 / 4.2	
	Correction of cos φ	-	0.96 / 1	
DIMENSIONS & WEIGHT	Height x width x depth	mm	ecoGEO+ B: 1058x600x710 / ecoGEO+ C: 1845x600x720 & AU22: 900x1800x600	
	Empty weight (without packaging)	kg	ecoGEO+ B: 193 / ecoGEO+ C: 255 & AU22: 175	

- Air-to-water by means of a brine-to water heat pump combined with a hydraulic outdoor air unit.
- In compliance with EN 14511, including circulation pumps, fan and compressor driver consumptions.
- Production flow rate according to EN 14511.
- Considering a heat slope from 20 to 50 °C in absence of consumption.
- Considering support provided by an emergency electrical heater or HTR. Max. DHW temp. with HTR can be limited by the compressor discharge temp.
- In compliance with EN 12102.
- Starting current depends on the working conditions of the hydraulic circuits.
- The admissible voltage range for proper operation of the heat pump is ±10%.
- Maximum consumption can vary significantly according to working conditions, or if the compressor's operation range is restricted. Consult the technical service manual for more information.
- Certification in process.

Dimensions and hydraulic connections

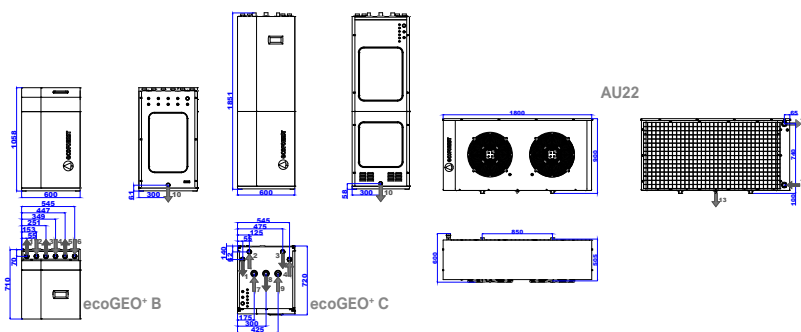

- Heating/Cooling outlet 1 1/2" M
- Heating/Cooling inlet 1 1/2" M
- Brine outlet 1 1/2" M
- Brine inlet 1 1/4" M
- DHW system outlet 1 1/2" M
- DHW system inlet 1 1/2" M
- CW inlet 1" H
- DHW outlet 1" H
- DHW recirc. inlet 3/4" H
- Drain 16mm
- AU source inlet 1 1/2" M
- AU source outlet 1 1/2" M
- AU drain 16mm

Available pressure drop

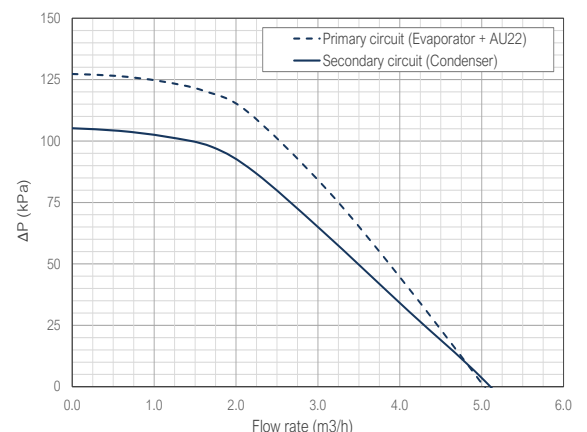

Heating W35

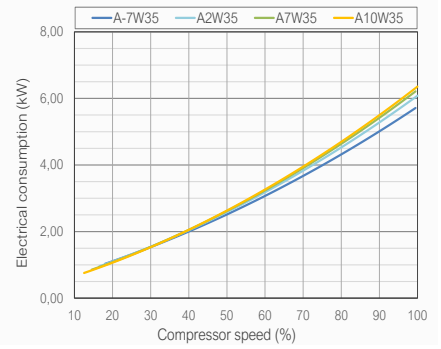
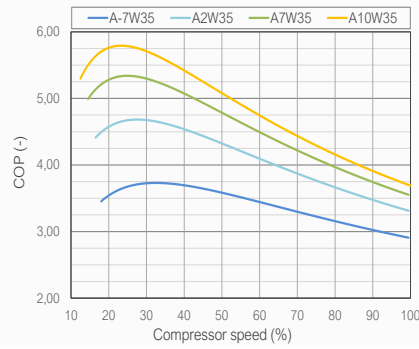
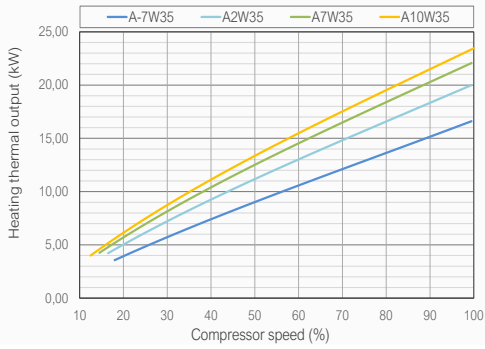

Heating W45

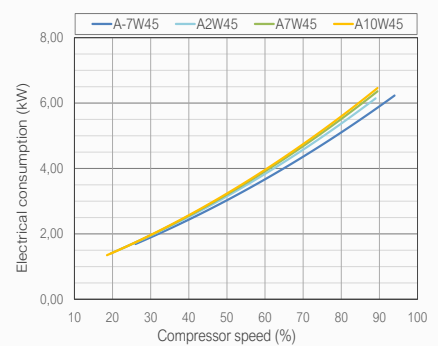
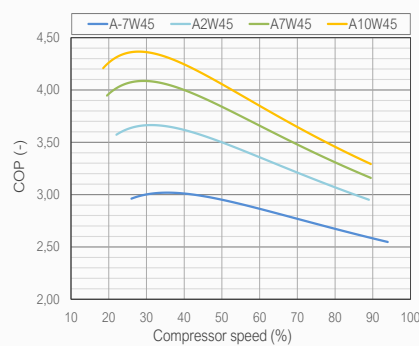
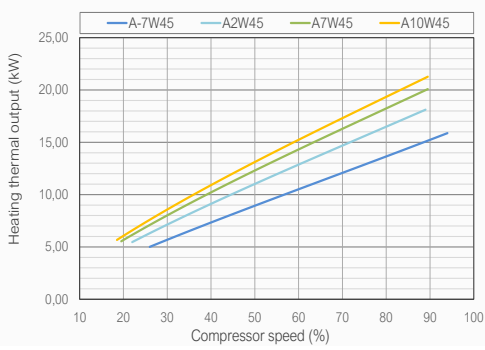

Heating W55

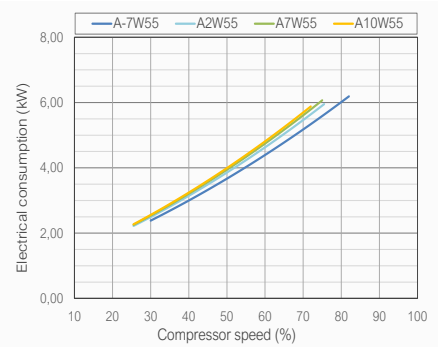
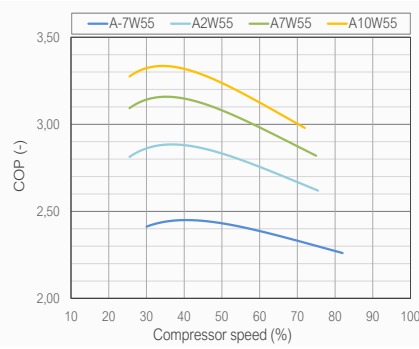
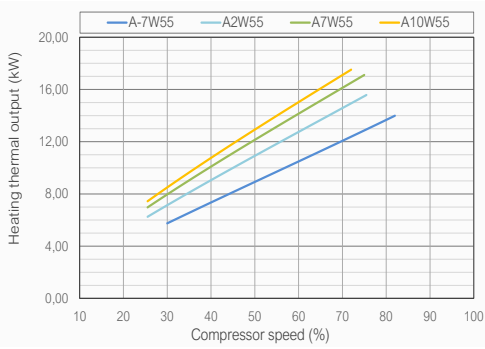

Cooling W7

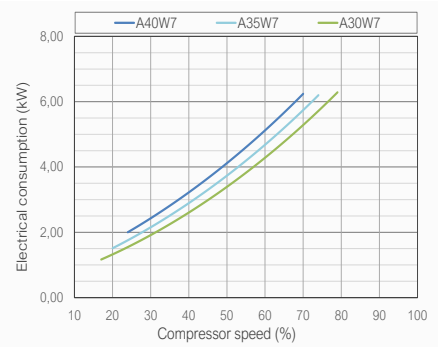
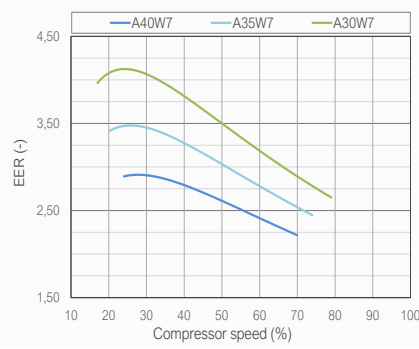
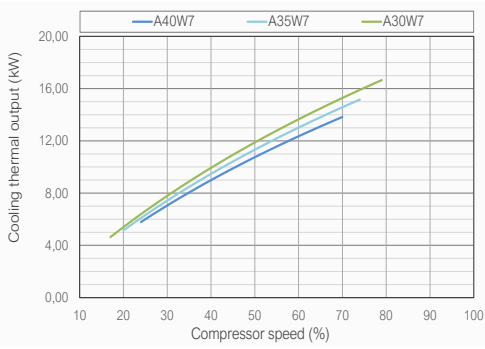

Thermal power - Outdoor temperature

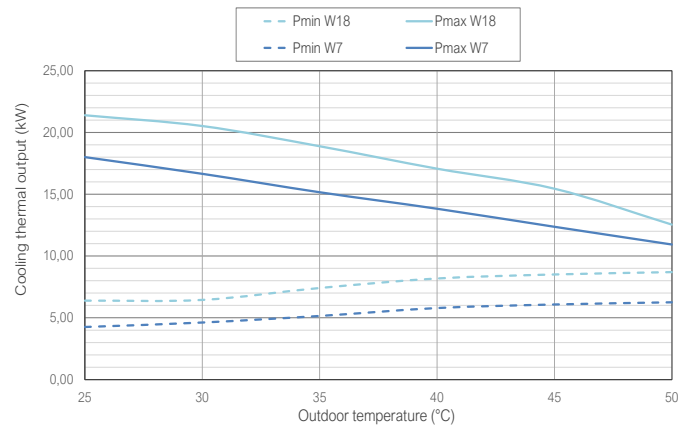
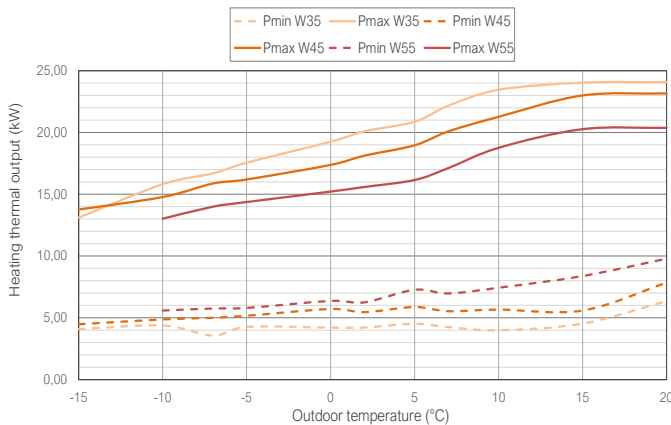



May 2026